



Cambridge Crystal Ball

Published monthly by National Cambridge Collectors, Inc.
to encourage and report the discovery of the elegant and boundless product of the
Cambridge Glass Company of Cambridge, Ohio

Issue No. 251

March 1994

1994 AUCTION

by Lynn Welker, Auction Chairman

[Editor's Note - This article arrived too late to be included in the February issue. We hope that the Post Office and the weather will cooperate so that you receive this before the Auction]

We hope that you will come to the Auction which supports the Museum Fund. If you cannot attend the Auction, try mail bidding this year. Our mail bidders have been successful in the past and their support really helps the Auction. Don't forget the Quarterly Meeting and Preview Friday night.

This year's Auction has a very wide variety of unusual shapes, decorations, colors and figurals. In addition, there are about 50 more lots this year. We hope this will offset the additional cost of using the Pritchard Laughlin Civic Center. Lunch will be available at the Center.

Several rarer shapes are included this year. Among them are: lot #176 Mandarin Gold cakestand, #244 - #246 pressed Rose Point stems, #247 Light Emerald goblet with golfball variant stem, #314 Carmen jigger stopper and #337 Moonlight Blue Star bowl. Other seldom seen items are: lot #44 Carmen Mt. Vernon 3-lite candlesticks, #120 Carmen Sweet Potato vase, #151 Crown Tuscan display urn (note wear), #169 3-lite candelabrum and #171 Amber Valencia etched 17½" cabaret plate. A complete Crystal etched Apple Blossom and Ebony luncheon set, lot #70, and #71 American Flint Glass Workers badge that belonged to Cambridge Glass worker, Oscar

McCollum round out unusual pieces in the Auction.

Many unusual Nearcut items will be sold this year such as lot #125 Wheat Sheaf child's punch set, #126 electric portable lamp, #131 Emerald Thistle nappies, #135 miniature 3-prong candlestick and #141 red flashed souvenir mug.

The Caprice line is very well represented this year by Lots #271 - #307. Some rarer Caprice pieces are: #272 celery, #273 butter lid, #280 reflector candlestick, #294 Moonlight Blue 3-lite candlestick, #299 Moonlight Blue 12" relish and #303 - 306 colored Caprice vases.

The #3011 Nude (Statuesque line) has some very nice examples in this year's auction. These lots are: #73 Gold Krystol claret, #74 Heatherbloom brandy, #80 Royal Blue ashtray, #105 Amethyst comport and #106 Forest Green champagne. The Carmen insert in Farber Nude comport, lot #147, is very unusual. The Nudes are rounded out by lot #149 Gold Krystol brandy, #150 Tahoe Blue cocktail, #190 Pearl Mist comport, #239 Crystal comport, #253 Emerald ashtray and #267 Royal Blue goblet.

Other figurals in the Auction are the unusual #20 Dolphin hurricane bases with Charleton Ivy decoration, Swans #19, #42, #87, #88, #174, #175, #192 and #193. Three Peach-Blo 13" Draped Lady flower

Continued on page 16

Cambridge CRYSTAL BALL

Official Publication of National Cambridge Collectors, Inc. a non-profit corporation with tax exempt status. Published once a month for the benefit of its members. All rights reserved; reproduction in whole or in part without written permission of NCC and the author is prohibited. Membership is available for individual members at \$17 per year and additional members (12 years of age and residing in household) at \$3 each. \$12.00 of the \$17.00 annual dues is for a 1 year subscription to the Cambridge CRYSTAL BALL. All members have voting rights, but only one CRYSTAL BALL will be mailed per household. Foreign mailings subject to a postage surcharge. Back issues of the CRYSTAL BALL are available (beginning with Issue No. 1, May 1973) for members only. Cost: \$1.00 each or 12 issues for \$10.00.

1993-94 Officers & Committee Chairpersons

President	Joy R. McFadden
Vice-President	Mark A. Nye
Secretary	Richard Jones
Treasurer	David B. Rankin
Sergeant-at-Arms	Cynthia A. Arent
Acquisitions	Joe Andrejcek
Budget & Finance	David B. Rankin
By-Laws	Charles Upton
Membership	Jeff Ross
Museum Expansion/Relocation	Willard Kolb, J. D. Hanes
Museum--Facilities	Doyle Hanes
Museum--Interior	J. D. Hanes
Non-Glass Items	Judy Momirov, Tarzan Deel
Nominating	Mark A. Nye
Program	Willard Kolb
Project	Tarzan Deel
Publications	Mark A. Nye
Public Relations	Mark A. Nye
Publicity	Cynthia A. Arent
Study Group Advisor	Judy Momirov
1994 Auction	Lynn M. Welker
1994 Antique Show	Mary Beth Hackett
1994 Convention	Mark A. Nye
1994 Flea Market	Mike Arent
CRYSTAL BALL Editor	Sue Rankin

Classified Advertising Rates

10 cents per word \$2.00 Minimum
We cannot mix type size in classified advertisements. Abbreviations and initials will count as words. Payment in full must accompany all ads.

Display Advertising Rates

(Camera-ready ads preferred)	Members	Non-Members
1/8 page	\$10.00	\$15.00
1/4 page	15.00	25.00
1/2 page	25.00	35.00
3/4 page	35.00	50.00
Full page	45.00	60.00

Dealers Directory

Six-line maximum \$24.00 for 12 months

Cambridge CRYSTAL BALL assumes no responsibility for items advertised and will not be responsible for errors in price, description or other information.

Advertising copy, articles, club news and notices must be in our P.O. Box by the 5th of each month to assure publication in our next issue.

Paid advertisements containing reproductions or new glass will not knowingly be accepted for publication.

Opinions or information stated in any signed article or letter printed in the CRYSTAL BALL are those of the authors and may or may not agree with National Cambridge Collectors, Inc. The Editor reserves the right to refuse and to edit any material submitted for publication to conform with the editorial style of the CRYSTAL BALL.

Please Address All Correspondence to:

National Cambridge Collectors, Inc.
P.O. Box 416, Cambridge, Ohio 43725-0416
President -- Joy R. McFadden 614/885-2726
Secretary -- Richard Jones 914/631-1656
Editor -- Sue Rankin 513/833-4626
NCC Museum /J. D. Hanes -- 614/432-4245

Please notify us immediately of any change in your address.

Please enclose an SASE when requesting information.

CAMBRIDGE GLASS BOOKS FOR SALE

By National Cambridge Collectors, Inc.

- **Colors in Cambridge Glass ***
128 pages, 60 color plates, fully indexed
Hardbound with price guide. \$19.95
 - **1930-34 Cambridge Glass Company Catalog Reprint ***
250-page reprint of original catalog
Paperback with price guide. \$14.95
 - **1949-53 Cambridge Glass Company Catalog Reprint ***
300-page reprint of original catalog
Paperback with price guide. \$14.95
 - **1956-58 Cambridge Glass Company Catalog Reprint ***
164-page reprint of original catalog
Paperback. \$6.95
- * For NCC members only, the above publications are available at a 10 percent discount.

By Bill and Phyllis Smith

- **Cambridge Glass 1927-1929**
66-page reprint of original catalog
Paperback w/identification guide. \$7.95

By Cambridge Buffs Study Group

- **Nearcut**
108-page reprint of 1910 Cambridge catalog
Paperback with price guide. \$9.95
- **Price Guide**
Updated price guide for Nearcut Catalog reprint (including postage). \$3.00

By Mark A. Nye

- **Cambridge Rose Point**
94 pages, fully indexed
Paperback with updated value guide. \$12.95
- **Value Guide**
Updated value guide for Rose Point book (including postage). \$5.00

By Mary, Lyle and Lynn Welker

- **Cambridge Glass Company**
120 pages of reprints from eight old catalogs
Paperback. \$10.00
- **Cambridge, Ohio Glass in Color II**
Spiralbound. \$5.95

By Harold and Judy Bennett

- **1903 Cambridge Glass Company Catalog Reprint**
106-page reprint of an original catalog
Paperback. \$7.50

Address your orders to:

Books
National Cambridge Collectors, Inc.
P.O. Box 416
Cambridge, OH 43725-0416

Please add postage and handling to your order (first book, \$2.00; each additional book, 50 cents). Ohio residents add 6½ percent state sales tax.

Dealer discounts available - please write!

The Making of Flower Holders

by Mark A. Nye

Have you ever wondered how glass flower holders were made? More specifically, how the holes were made? One of the patents held by Arthur J. Bennett was No. 1,179,155, Method of Making Flower-Holders. The application for the patent was filed on June 30, 1915, and his method was granted patent protection April 11, 1916. In this article the text of the patent and the drawings that accompanied it are presented. The method for making this style of flower holder is clearly explained.

To all whom it may concern:

Be it known that I, Arthur J. Bennett, a citizen of the United States, residing at Cambridge, in the county of Guernsey and State of Ohio, have invented new and useful Improvements in Methods of Making Flower-Holders, of which the following is a specification.

This invention relates to new and useful improvements in method of making flower holders, and the primary object of the invention is to provide an improved method for the manufacture of blocks from molten material for holding and supporting flowers.

Briefly, the invention contemplates the placing or pouring of sufficient molten glass into a mold to form a block or holder; inserting a plunger into and through the body, such operation producing small teats or protuberances projecting below the bottom; removing the mold; inverting the body and supporting the same without the use of any mold, to allow the glass which is to form the top to fall or sag from the increased body portion under the influence of its initial heat; and finally removing the protuberances from the bottom of the body to provide openings extending entirely through the body.

A full understanding of the invention will be obtainable from the following description in connection with the accompanying drawings in which:

Figure 1 is a sectional view of a mold with the glass material therein and the plunger inserted for forming the flower stem receiving opening; Fig. 2 is a similar view of a support for holding the glass block in inverted position, the block being in elevation; Figs. 3, 4 and 5, show different methods of supporting the

glass block inverted to permit of the top-forming glass to sag and form the top of the block.

The mold employed in the present method preferably consists of three sections and a core or plunger member. The base mold section 1 is recessed, as at 2, and the bottom wall of the recess is provided with a plurality of depressions or indentations 3 which are preferably arranged in concentric series. The intermediate mold section 4 is nested in the recess 2 of base section 1 and is formed in its top wall with a recess 5 from which leads an opening 6 through the section, said opening being disposed to surround or include the depressions 3.

Nested in recess 5 is the top mold section 7 which is formed in its bottom wall with a recess 8 and a counterbore or enlargement 9 to form a shoulder 10 on the block or flower holder 11. Extending through the top section 7 from recess 8 and arranged in coincidence with the depressions 3 is a plurality of openings 12 through which the plungers 13 are inserted. These plungers are supported by a suitable head 14 and are of sufficient length to extend below the bottom wall of recess 2 into the depressions 3, said plungers tapering downwardly from the openings 12. The cross sections of openings 6 and recesses 8 and 9 may be of any desired contour.

The molten glass, or other material, is placed in the sectional mold and the plungers 13 inserted (see Fig. 1) thereby forcing the glass into the recesses 8 and 9 of the top mold section 7 to procure the initial part of the top curvature, or an increased body or superstructure of glass 11' [eleven prime]. The block is then removed from the mold and plungers and supported in an inverted position from its shoulder 10 engaging with a ring 15 of a stand as shown in Fig. 2. When inverted, the central portion of the block being still hot will fall or sag into free space, and without the presence of a mold and under the influence of the initial heat from the super or increased body structure into an undefined form of the general contour shown. Due to the sagging or falling of the central mass, the base or, as disposed in Fig. 2, the upper part of block 11 will probably be slightly deformed by contraction at that point and the curvature of the side wall increased. But for the sake of clearness, the finished curvature of the block 11 is

shown practically of the same general contour as that of the mold. The small protuberances 16, which are formed by the depressions 3 and made hollow by the plungers 13 entering the latter, are then removed from the bottom of the block by breaking them off to complete the openings entirely through the block.

In lieu of supporting the block inverted by the construction shown in Fig. 2, other methods may be advantageously employed as depicted in Figs. 3, 4 and 5. In Fig. 3, a "punty iron", consisting of post 17 and iron plate 18, is used which, when hot, will readily adhere to the hot glass protuberances 16 and allow the block to be supported in an inverted position. Fig. 4 shows an automatic flange snap 19 for engaging over a slight projection or foot 20 specially formed on the bottom of the block, or the snap may be conveniently applied to the block shoulder 11 as illustrated in Fig. 5.

Although glass is specifically mentioned herein, it is understood that other similar material may be used with equally as good results. Furthermore, it is not the intention to limit the invention to any particular shape of resultant product, since various and fancy forms are contemplated, such as oval, square, etc.

With use of a punty and snap, the formation of the mold could be changed so as to eliminate the shoulder 10 and continue the curvature into the superbody portion.

In connection with the mold, it will be noted that three sections are not essential, since the two lower sections 1 and 4 may be united or integrally formed to thereby provide a mold comprising two sections.

The above mentioned and other obvious changes are announced as falling within the spirit and scope of the invention as defined by the appended claims.

What is claimed is:

1. The hereindescribed method of making a glass flower-holding block which consists in molding a body with a shoulder and a superbody portion extending from the shoulder, providing a plurality of openings through the superbody portion, and inverting and supporting the block from its shoulder while the superbody portion is in partial molten condition to permit of the latter sagging unsupported into an undefined shape.
2. The hereindescribed method of making a glass

flower-holding block which consists in molding a body, providing an opening in the top wall thereof, inverting the body while the central portion is partially molten, and supporting the body at a point above the inverted top wall to allow the partially molten portion sagging from the top wall into an undefined shape.

3. The hereindescribed method of making flower-holding blocks, which consists in placing glass in a mold, forming an opening in the block, removing the mold and inverting the block while the central top portion is still hot to permit of that portion sagging into an undefined shape to complete the top for the block.

4. The hereindescribed method of making flower-holding blocks, which consists in placing glass in a mold having a shoulder-forming recess and a removable part formed with a superbody-forming recess, inserting a plunger into the glass to force the same up into the recess of the mold and provide an opening in the block, removing the part provided with the superbody-forming recess and inverting the block while the central portion of the block is still hot to allow that portion to sag from the superbody part into an undefined shape.

5. The hereindescribed method of making a flower-holding block, which consists in placing glass in a mold having a shoulder-forming recess and a superbody-forming recess, inserting a plunger entirely through the glass block to form a protuberance on the bottom of the block and whereby the material is forced into the recesses of the mold, inverting the block and supporting it by its shoulder while the central top portion of the block is hot to allow that portion to sag, and then removing the protuberance to complete the opening through the block formed by the plunger.

6. The hereindescribed method of making a glass flower-holding block which consists in molding a body with a superbody portion having a flat top, providing openings through the top of the superbody portion, and, while the latter is in a partially molten condition maintained so by the residual heat, inverting the body to allow the superbody portion sagging into space undefined.

In testimony whereof I have hereunto set my hand.

ARTHUR JAMES BENNETT.

A. J. BENNETT
 METHOD OF MAKING FLOWER HOLDERS
 APPLICATION FILED JUNE 30, 1915

1,179,155

Patented Apr. 11, 1916

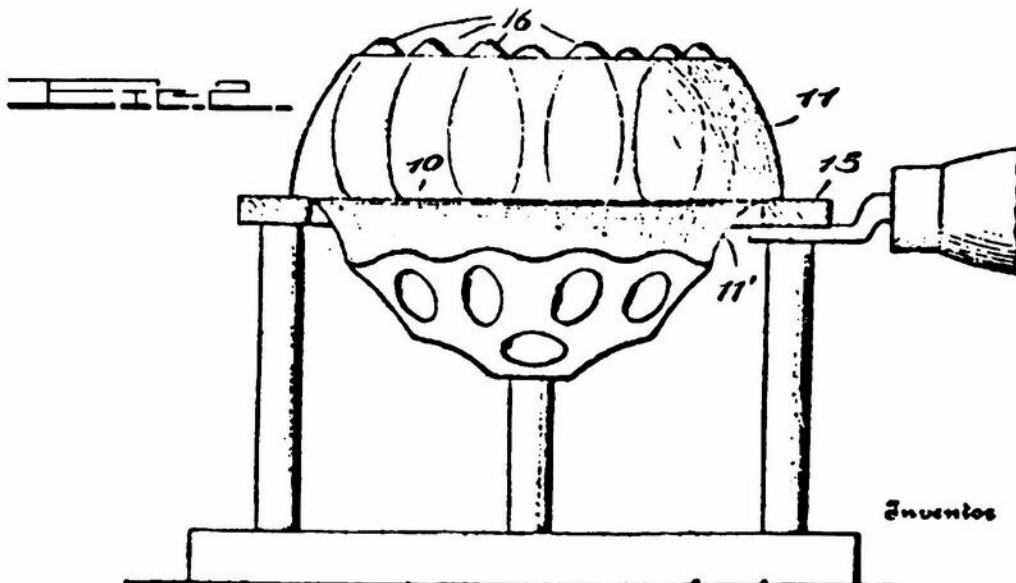
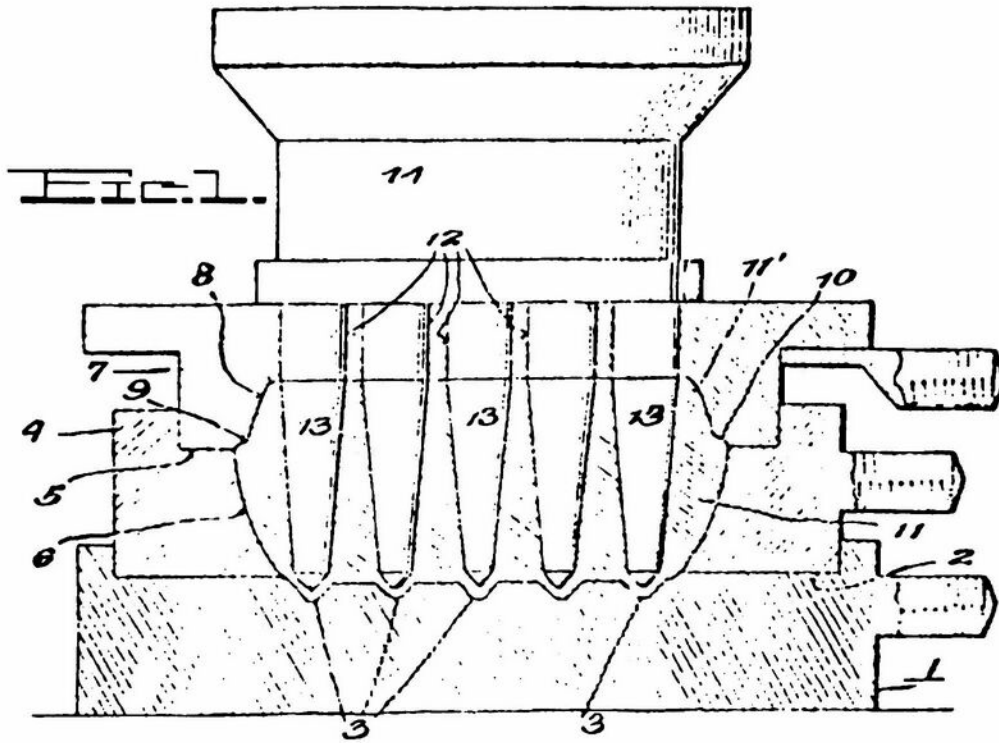

Inventor

Arthur J. Bennett
 By *[Signature]*
 Attorney

A. J. BENNETT
METHOD OF MAKING FLOWER HOLDERS
APPLICATION FILED JUNE 30, 1915

1,179,155

Patented Apr. 11, 1916

2 Sheets - Sheet 2

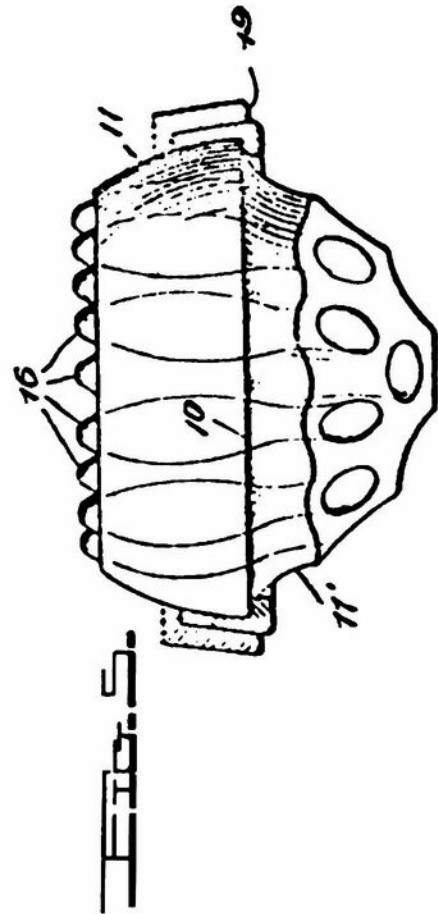
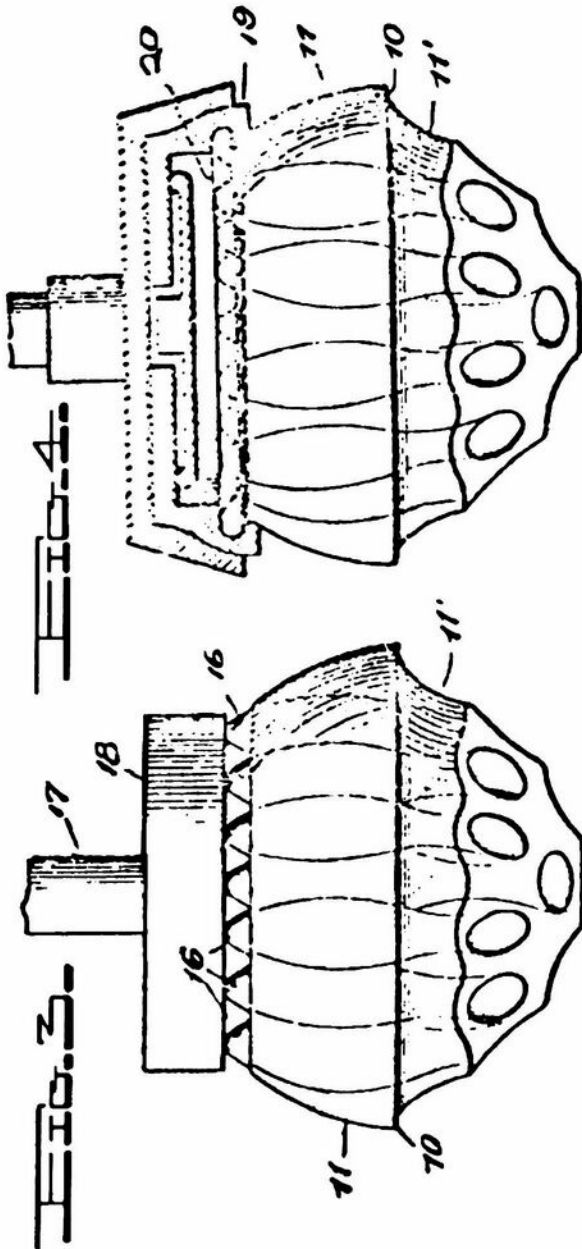

Arthur J. Bennett Inventor
P. J. Press Attorney

METHOD OF MAKING FLOWER-VASE INSERTS

PATENTED NOV. 9, 1926

1,606,687

This invention relates to certain new and useful improvements in method of making flower vase inserts and the primary object thereof is to provide a simplified method for enabling the inserts to be expeditiously and economically produced.

A further object of the invention is to provide a method which enables the inserts to be produced by pressing, as distinguished from blowing thereby to assure uniformity in production.

The invention has still further and other objects which will be later set forth and manifested in the course of the following description.

In the drawings:--

Figure 1, is a side elevation, partly in section on line 1--1 of Figure 2, showing the pressing of an insert;:

Figure 2, is a section on line 2--2 of Figure 1;

Figure 3, is a side elevation of the completed insert, and

Figure 4, is a top plan view of Figure 3.

In proceeding in accordance with the present invention, a mold is employed composed of two complementary sections 1 and 2 which are hinged together at 3. The base of the mold is formed with a circular cavity 4, having a bottom wall 6, the circumferential wall of the cavity being formed with spaced annular grooves 5. The body 18 of the mold is formed with a chamber or cavity 7 conforming to the external shape which the insert is to possess and is further provided with an upper extension 8 in which latter the spikes or fingers 12 of the insert are formed. The wall defining the cavity or chamber 7 is further provided with spaced vertical grooves 9 and circumferential grooves 10 whereby the insert will be formed with corresponding longitudinal and circumferential ribs 11 and 13 respectively.

A plunger or pressure head 14 is movable into the mold chamber or interior and has a stem 15 the major portion of which, in external contour, conforms to the shape of the chamber 7. The lower extremity of the stem 15 projects below the lower end of the chamber 7 and into the cavity 4 and with its bottom 16 spaced from the bottom 6 of the cavity 4.

In order to form the spikes or fingers 12, a ring is

employed which includes a top 19 seating on the upper face of the body 18 of the mold and a depending circular collar 20 the latter being scalloped reversely to the scalloped formation which the spikes 12 present. The collar 20 engages against the circumferential wall of the chamber 7, and receives the plunger 14 on its interior. The plunger 14 is provided with a flange 17 which engages with the form top 19 and limits inward movement of the plunger relative to the mold.

In operation, the molten glass is placed in the mold and the plunger then forced therein, causing the spikes to initially have vertical disposition and the product a closed bottom 21 connected thereto by a neck portion 22. After cooling, the product is removed from the mold, placed in a snap and then heated, whereupon the spikes are turned over with a wooden paddle (not shown) to assume the position in the finished article, as depicted in Figure 3 of the drawings. The article is then allowed to slightly cool, is tempered, and the bottom part cracked off and ground, which completes the process.

From the foregoing it will be apparent that the pressing of the articles in a mold of any defined and desired shape not only assures uniformity in production, but enables more economical production, as compared to blowing, owing to the expense of skilled labor in making blown ware of this character. The inturning of the spikes is easily and quickly accomplished by the ordinary finishing process of rubbing in with a finishing tool, to the desired disposition, whereby the spikes will be caused to lie in a common plane and thus effect symmetry in appearance.

Obviously, the mold may be composed of more than two sections if desired, and a suitable finishing tool of any character employed, i.e., whether a wood or metal paddle or otherwise, and other changes resorted to as may fall within the scope of the claims.

The finished product is employed in connection with vases and is placed in the top of the vase to permit the use of but a few flowers in vases having large necks, and which otherwise would require the use of a large number of flowers to make an effective display as set forth in my Letters Patent No. 1,539,153 dated May 26, 1925. By use of the present product a

continued on page 16

Nov. 9, 1926

1,606,687

A. J. BENNETT

METHOD OF MAKING FLOWER VASE INSERTS

Filed March 12, 1924

2 Sheets - Sheet 1

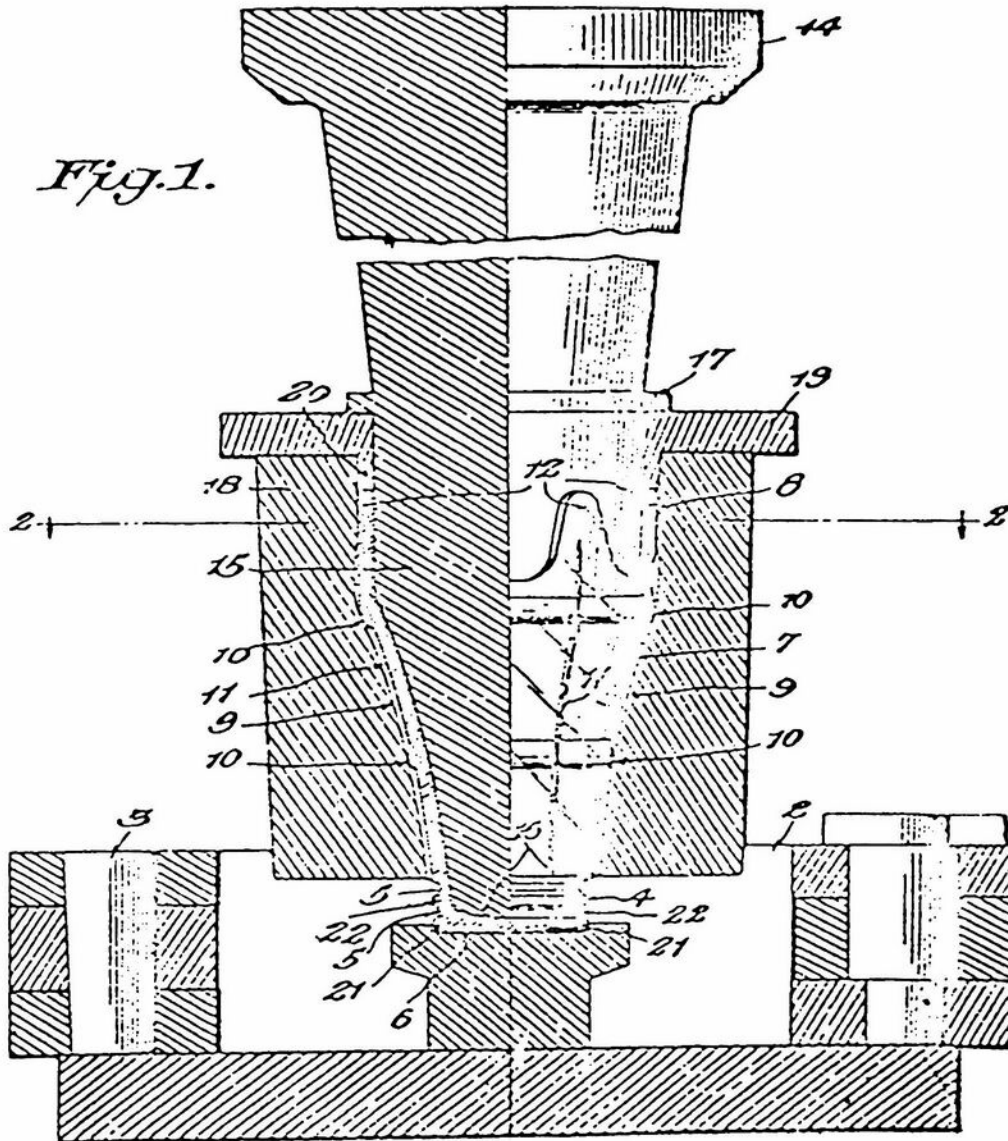

Arthur J. Bennett Invention

W. H. Mess Attorney

WITNESS:-
Chas. L. Cristman

A. J. BENNETT
METHOD OF MAKING FLOWER VASE INSERTS
Filed March 12, 1924 2 Sheets - Sheet 2

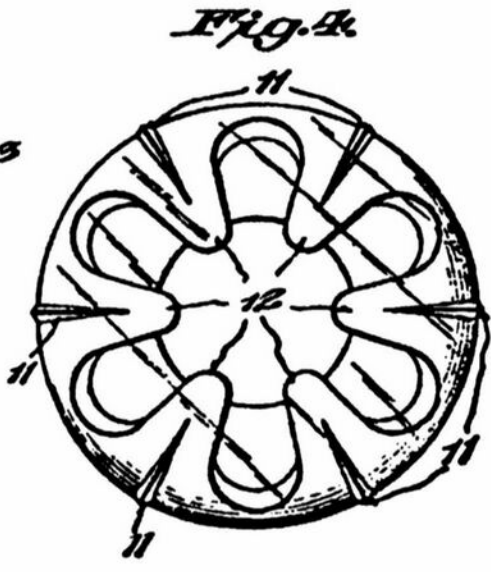
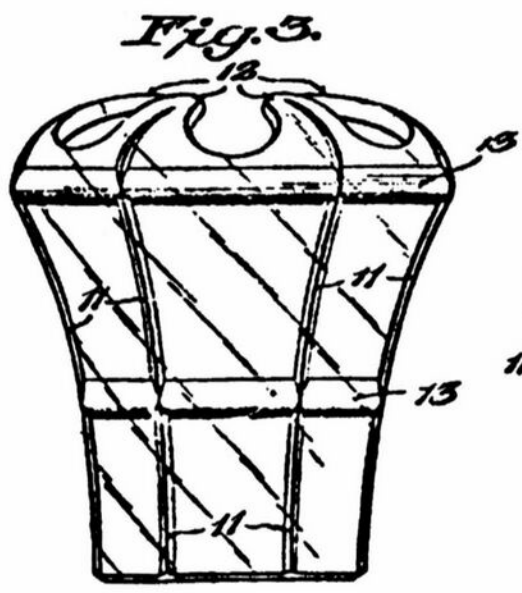
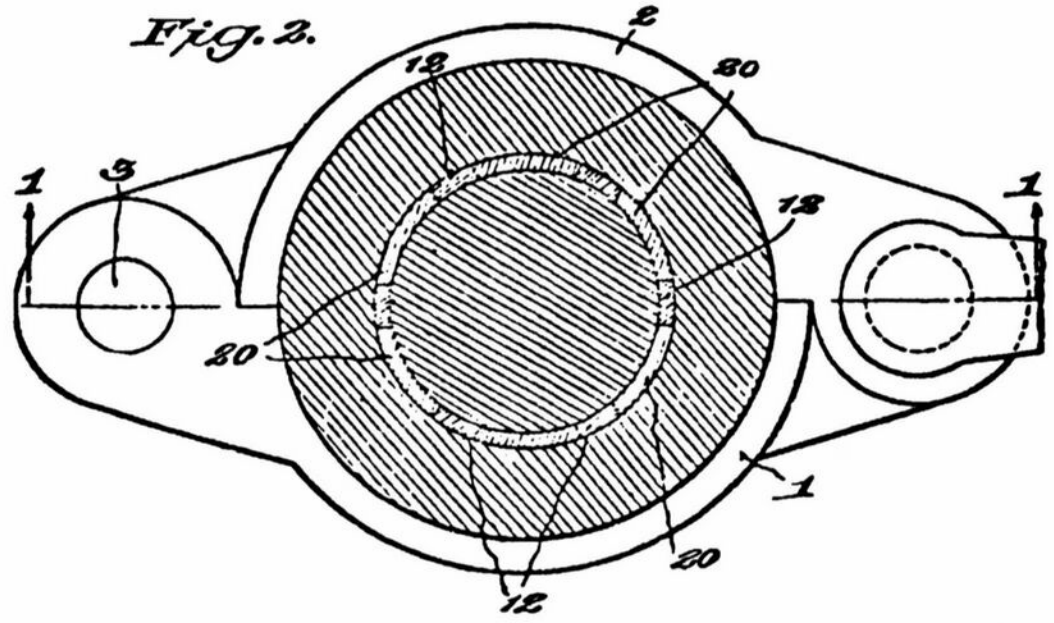

WITNESSES-
Chas. L. Cristobal

Arthur J. Bennett Invention
A. J. Bennett
Attorney

Convention 1994

The Roaring Twenties

by Mark Nye, 1994 Convention Chairman

As I write this, the high temperature for the day was -10°F and it is comforting to think about June and pool parties. By the time you read this, Spring will be just around the corner, the beginning of Summer will be in sight and that means Convention Time and the opening Pool Party.

The Roaring Twenties were an exciting time for both the country and the Cambridge Glass Co. It is the desire of the Convention Chairman and the Convention Committee to make the 1994 NCC Convention an exciting time for all those who attend.

Besides the convention souvenir, plans are in the works to have a souvenir booklet as well. It will contain Convention information together with articles and other information dealing with Cambridge and the 1920s that will not appear elsewhere this year. This booklet will be a part of the registration packet. The Convention Chairman would like to hear from a Study Group or an individual member willing to donate \$100 to defray the cost of printing the booklet. Credit will be given in the booklet and the donor, if not attending the Convention, will receive, free of charge, a Convention Souvenir. Your gift will be tax deductible to the extent allowed by law.

The Convention Committee would also be interested in hearing from a Study Group willing to sponsor an informal post banquet gathering.

One Cambridge line that had its origins in the 1920s is the figural flower frog. One of these, the Rose Lady, is being used as the 1994 Convention Logo. The drawing was adapted from the one used for the design patent application. (See page 16).

Details regarding Convention events and fees will be published in the April issue. While there will be an increase in at least the registration fee, each member attending will certainly receive their money's worth.

Make your plans now to attend the 1994 NCC Convention.

NCC GOLF TOURNAMENT

by Mike Arent

If you are a golfer and coming to this year's Convention, you may want to make sure there is room left in your car to bring your golf bag. As part of this year's Convention activities, we are exploring the possibility of having an NCC Golf Tournament the day before the Convention begins.

It is still a little too early in the year to lock in prices and tee times. If there are at least 12 golfers interested, a golf outing will be planned for Thursday morning, June 23 at Salt Fork State Park. This is a beautiful golf course approximately 8 miles east of Cambridge on Rt. 22.

To speed up play and make things fair for everyone, the tournament will be a Two-Man Scramble with randomly selected partners. A later issue of the CRYSTAL BALL and the Convention registration package will provide more details. If you need information earlier, call Mike Arent (614) 432-6383 between 9:00 a.m. and 5:00 p.m..

At this point, we do not know the level of interest to expect in a non-glass activity such as this. However, there are many of you that attend the convention as part of a larger vacation. So if you are planning to be in the area, keep Thursday open for golf.

CONTACT PERSONS

In the months ahead, many members will wish to contact various Chairmen of Convention related activities. We include a list of the Chairpersons, all of whom may be contacted through the NCC PO Box or by calling the numbers provided.

Convention Chairman

Mark Nye
(517) 592-6200

Antique Show Chairman

Mary Beth Hackett
(614) 885-2726

Flea Market Chairman

Mike Arent
(614) 439-4582

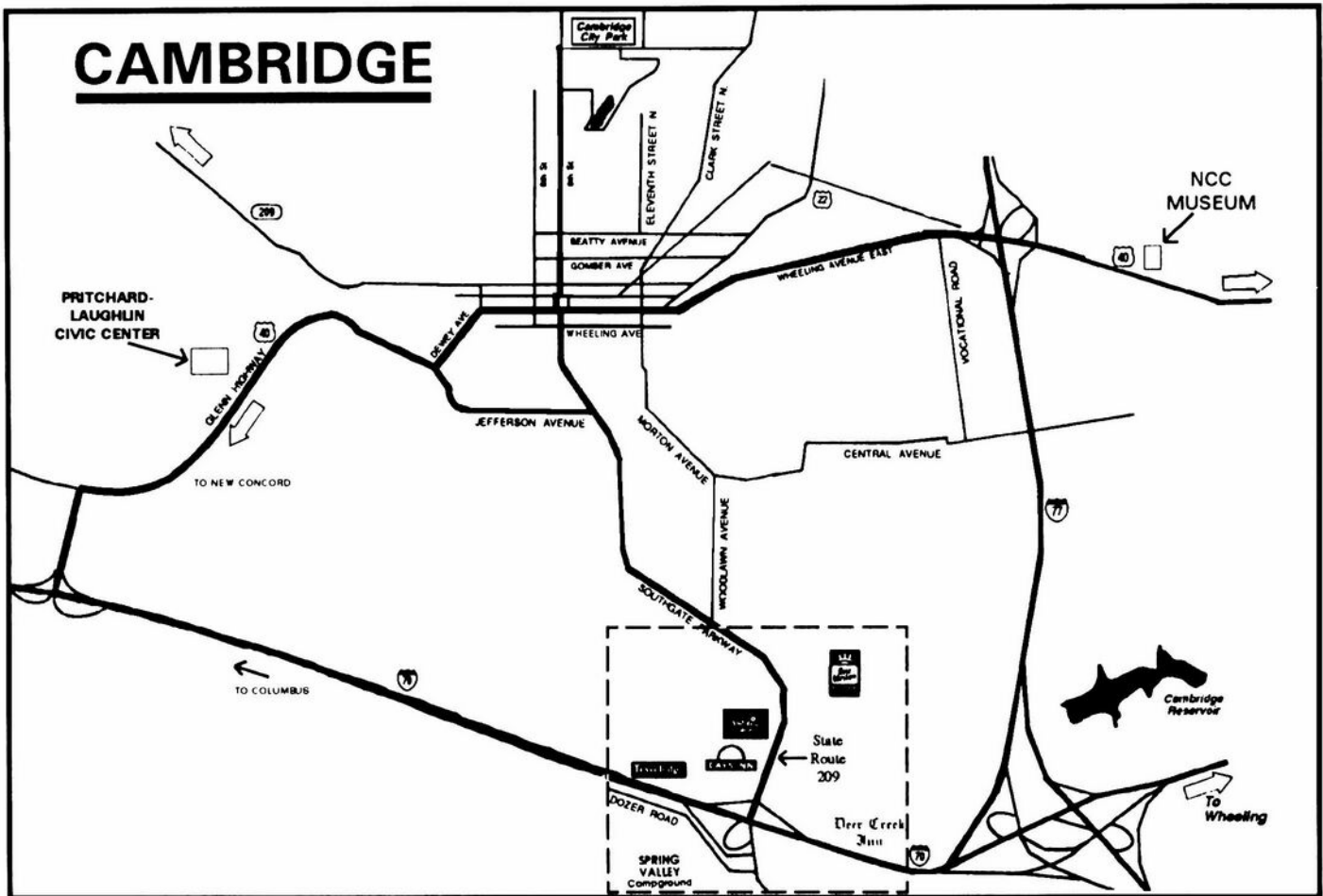

BRIEF MOTEL INFORMATION

CAMBRIDGE FAIRDALE INN

6405 Glenn Highway, Cambridge, Ohio 43725. 614-432-2304. Located at the intersection of Interstate 70, Exit 176 and U.S. Routes 22 and 40, No extra for children. One week cancellation notice. Approximately 6 rooms available. No rate available.

The following motels are all located at Exit 178 off of Interstate 70 which is Route 209.

DEER CREEK MOTEL AND RESTAURANT

2325 Southgate Parkway, Cambridge, Ohio 43725. 614-432-6391. For reservations, call 1-800-637-2917. 24 hour cancellation notice. Approximately 80 rooms available. [Flooded in January, expect to reopen in May] No rate available at this time.

BEST WESTERN CAMBRIDGE

1945 Southgate Parkway, Cambridge, Ohio 43725. 614-439-3581. No extra for children. One week cancellation notice. Approximately 50 rooms available. \$49.00 single or double.

HOLIDAY INN-CAMBRIDGE

PO Box 1270, Cambridge, Ohio 43725. 614-432-7313. One week cancellation notice. Approximately 30 rooms available. \$75.00 single or double.

CAMBRIDGE TRAVELODGE

PO Box 158, Southgate Parkway, Cambridge, Ohio 43725. 614-432-7375. One week cancellation notice. Approximately 15 rooms available. \$50.00 single,

\$55.00 double with 1 bed, \$59.00 double 2 queen size beds. NCC members with ID get 15% off.

DAYS INN CAMBRIDGE

2328 Southgate Parkway, Cambridge, Ohio 43725. 614-432-5691. Children free. Cancellation policy depends on type of reservation. Approximately 45 rooms available. \$85.00 single or double.

The map below shows an enlarged area around the intersection of Interstate 70 and state route 209 where most of the motel rooms can be found.

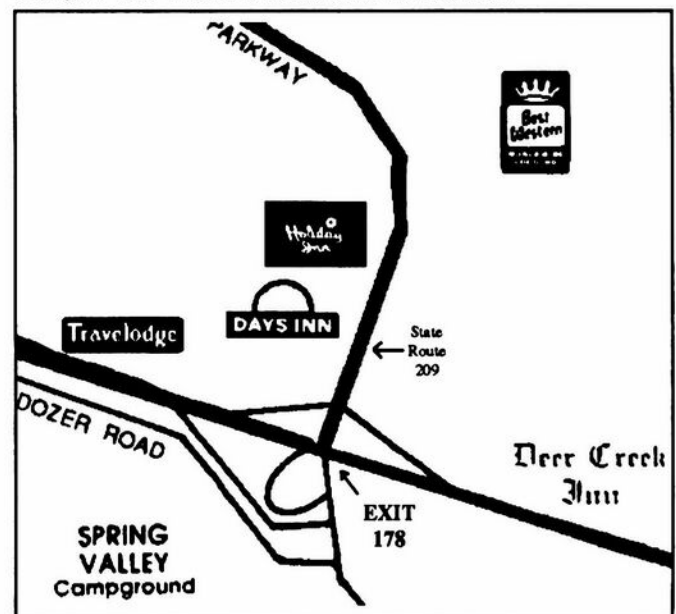

Study Club News

Study Group #16 - Mid-Atlantic "Elegant Glass Collectors"

The Elegant Glass Collectors met at the Museum of American Glass at Wheaton Village, in Millville, New Jersey. The museum's annual Antique Show is held right in the museum and an adjacent building.

Purchased at the Antique Show were a #3200 twelve inch Crystal Cut Wild Rose Cylinder Vase, a #2588 footed fruit bowl and a pair of Crystal #2759 miniature 3-lite candelabra.

Show and Tell items included a Doulton Jug Pitcher with six barrel tumblers in the rarely seen Jade Green (Forest Green with the outside frosted and inside polished), a Royal Blue and a Carmen Mount Vernon 14 oz. handled mug.

The Wheaton Village museum has a growing collection of beautiful Cambridge Glass, along with all their other beautiful glass. The Walker Collection included an Azurite Ram's Head bowl with Doric Candlesticks, a Crown Tuscan comport, a Crown Tuscan covered shell footed candy dish, a painted Crown Tuscan shell dish, a Crystal nude comport, and other pieces, most notably a footed Amethyst Japonica 3400 bowl.

The next scheduled meeting will be at the Auction, March 5, 1994, and then at the Convention in June 1994.

Submitted by
Pam Earussi

Study Group #15 - North Texas Cambridge Collectors of North Texas

On December 13, 1993, thirteen members and two guests gathered at the home of Tom and Margaret Bowman. The primary purpose of our gathering was to celebrate the Holiday Season with good friends around an elegant table, reminiscent of the days when elegant Cambridge glass graced tables all over America and beyond. Fifteen people were seated at two tables. The "Heisey" table was in the formal dining room, where a Spanish lace tablecloth overlay a Christmas red undercloth. The music room and hall were decorated with a dozen red poinsettias and

bright wide red velvet ribbons. The table centerpiece was live evergreen with tall red candles in Heisey orchid double candlestick holders surrounded by bunches of artificial cherries. The table was set entirely in Heisey orchid crystal: dinner plates, salad plates, cups and saucers, and stemware, as well as all of the serving pieces.

Tom and Margo also had a "Cambridge" table in soft gold and blue to follow the decor of their glass display room, where the table was set up. The dinner plates were plain 3400 in Moonlight Blue, with blue Cleo salad plates and cups and saucers. The stemware was 1066 in Moonlight Blue, with a blue Gyro Optic ball jug and blue Cleo serving pieces. These were set on a pale yellow table cloth. The centerpiece was live evergreen with blue juniper berries and gold bells, with two 3-candle Cambridge arms to hold a total of seven white Christmas candles. On side tables were blue Cleo candlesticks with more white candles.

Each guest brought a covered dish, and Tom and Margo provided a baked ham. Following the meal, we had a blind gift exchange. The goal was to find a "treasure," Cambridge of course, which cost less than \$10.00 for the exchange. It was fun to see what each giver had been able to locate. The National Cambridge Club has done such a good job educating the public about fine Cambridge glass that it is becoming harder and harder to locate a piece that has not been identified by its seller, and coincidentally marked with an inflated price, as well. Among other things, gifts included a Crown Tuscan 4-inch shell dish, a blue Cleo salad plate, three of four 3500 candy dishes in crystal and colors, some Caprice ashtrays, and an Amber 8-inch plate with an etching (I don't recall which one.)

While those who love football joined Tom in the den and watched our beloved Cowboys on the big screen, the rest retired to the glass room and conversed over coffee. We all had a wonderful time, and we urge other clubs to take time out occasionally from "business," and just enjoy the pleasure of fellowship and our beautiful Cambridge glass.

By the time this appears in the CRYSTAL BALL, we will have had our January meeting at Pat Glaser's home. As a reminder, dates and hostesses for the remainder of the Spring are as follows:

Sunday, January 16 at 2 p.m.
Hostess: Pat Glaser, Richardson, Texas

Topic: 3011 or Statuesque line (Cambridge Nudes)

February 20: Hostess: Mary Pfanensteil,
Topic: Reproductions and Fakes. Members need to get information to Margo ASAP, so she can assemble the handouts.

March 20: Hostess: Betty O'Grady,
Topic: Cambridge Animals, Flower Frogs and Figurals

April 17: Open Date.

May 15: Hostess: Benna Jones
Topic: undecided.

Note from your editor

Our Members in California

The pictures of the earthquake shown on television were devastating. We hope that you all came through safely. To date, we have heard from two California members who sustained no damage. We sincerely hope that this is true for all.

The Post Office

For those who are not aware of how NCC handles day to day activity, I will give you a brief idea.

All mail to NCC goes to the Post Office box. J. D. Hanes collects the mail and generally sends it once a week to the appropriate people with a cover sheet which summaries the contents of each transmittal.

Since the CRYSTAL BALL deadline is the 5th of the month, J. D. makes a special effort to send articles and ads to me on that date. We start work on each issue on or before the 10th and deliver it to the printer by the 15th.

I live 160 miles from Cambridge and the normal postal delivery is two days - until this month. J. D. sent two ads and two letters to me on the 5th. As of the 14th, they have not arrived.

Dave, in his capacity as Treasurer of NCC, received copies of the checks included with the two ads (J. D. deposits the checks). Neither check contained a phone number. One was from a member with an unlisted phone number so I was unable to contact

her to get the ad copy. The second ad is from a nonmember whom I was also unable to contact. I hope this mail will turn up in time for the April issue.

When I went to the Post Office to put a trace on this lost mail, I saw a banner behind the counter reading:

**You get it here
We'll get it there**

They didn't say WHEN!

Now I know why many businesses make extensive use of fax machines for their time-sensitive materials. We may have to do the same.

J. D. also included a "Museum Moments" article for this issue. J. D. attempted to get to the museum to produce a replacement copy. However, the main access to the museum was blocked by ice and snow. An attempt at an alternate approach on foot from the back also failed. We hope your bruises heal soon, J. D.!

We will look for this article next month. Meanwhile, J. D. said that "Thank You" letters for all 1993 donations have been mailed. If you made a donation in 1993 and have not received a letter, please drop him a note.

IN MEMORIAM

Edward L. Trindle

Word has been received that, 1987 NCC Convention Banquet speaker and former member, Edward L. Trindle died January 25, 1994, in Oklahoma City after a long illness. Ed was a member from 1978-1989.

We extend our sincerest sympathy to his family and friends.

Sondra Wood

We were saddened to hear of the sudden death of Sondra Wood, long-time Caprice collector and member of NCC on December 24, 1993.

We extend our sincerest sympathy to her family and many friends.

President's Message

Did you ever hear the saying, "If it weren't for bad luck, you'd have no luck at all?" Well, I believe it.

This has been the worst winter in Ohio in a long time. Schools were closed almost a week in January due to extremely bitter cold and snow. Temperatures reached 25° below zero and the wind chill made it 50-60° below. My car started and I did not have the flu, but that's where my good luck ended.

Friday of that week, I found a dent in my fender left by an unknown assailant.

The week after the bitter cold, it began raining. Monday evening I hit a pothole in the road, which necessitated the purchase of three new tires. Early Thursday morning, the sump pump died and water came into the basement. Ordinarily this would not have been a tragedy, but I just had a family room built in the basement and the new carpeting was only four weeks old. What a mess!

While my neighbor and I were in the basement trying to clean up the water, my roommate came home and told us she had just been robbed at work.

Finally, I just learned I will have to have surgery on one or both of my hands.

Enough is enough!

As most of you read this, there is still time for you to attend the quarterly meeting on Friday, March 4 and the auction on Saturday, March 5. Your GOOD LUCK could begin when you make the final bid on the item of your choice at the auction.

Hope to see you there!



WE GET LETTERS

Dear Sue,

Mac and I would like to make comments concerning the sale of the Cambridge prism sign. Before we get into the matter, we want to make it clear that we know the need for raising money for the operation of the museum is imperative. We also realize the difficult task it is to come up with the ideas that would create the highest interest as far as marketability, and now comes the "however!"

We do not understand the idea of the "limited" number of prisms.

Since the Crystal Ball is used for distributing the order blank, we know each club member receives the order blank. Couldn't the procedure allow a "deadline" date to receive a "paid in advance" order? And then, couldn't this order be given to Boyd's Art Glass to be filled? There would not be any over runs and all those interested would have the prism!

Mac and I have seen disharmony brew in another glass club over the "limited number" method of sales for fund raising. The idea of fund raising, should be exactly that . . . RAISING FUNDS . . . for the mutual benefit of the entire club. There are over 1000 members in the NCC and we believe all members should have the opportunity of ordering any number of an item for any fund raising. Each member should have the opportunity to participate in the support of their museum. Wouldn't it be great if we could sell 500 or 1000, or more?

We do not feel it is the club's responsibility to create a future collectible with the "limited issue"; CAMBRIDGE GLASS IS THE COLLECTIBLE!

Very truly yours,
Mac and Georgia Otten
Ohio

Dear Georgia and Mac,

You make a good point. Others have expressed similar thoughts. The Board of Directors should give consideration to this.

Sue

AND PHONE CALLS

Kay Powell, Ohio, asked about any articles published regarding the Cambridge figural flower holders. I promised her an answer in the CRYSTAL BALL in case others might be interested.

Dear Kay,

The following articles were part of a series written by Bill Smith during the 1970s:

- Issue #17 - Rose Lady
- Issue #19 - Bashful Charlotte
- Issue #21 - Draped Lady
- Issue #34 - Eagle and Cockatoo
- Issue #35 - Turtle

Issue #38 - Mandolin Lady

Issue #40 - Geisha Girl

Issue #41 - Heron

Phyllis Smith wrote on the Turtle in Issue #98 and #101.

Issue #58 contains a chart listing the Miniature Animals, Bookends and Figural Flower Frogs and the colors in which they are to be found. In Issue #61 an updated chart was published covering only the Figural Flower Frogs. This chart is reproduced below with minor modifications.

Since this chart was originally published in May 1978, it is overdue for updating. If anyone has new information to add, please let us know.

Sue

FIGURE FLOWER FROGS

ITEM NUMBER	2nd ITEM NUMBER	BASE STYLE	CRYSTAL		AMBER		MOONLIGHT	MOONLIGHT	WILLOW	CARMEN	LIGHT	EMERALD	MANDARIN	PEACH-BLO	PEACH-BLO	CROWN	IVORY	MILK
			CRYSTAL	SATIN	AMBER	SATIN	BLUE	SATIN	BLUE	EMERALD	SATIN	GREEN	GOLD	SATIN	EBONY	TUSCAN		
2905		8 1/2" Draped Lady #1	X								X			X				
518	1118	8 1/2" Draped Lady #2	X	X	X	X	X	X	X	X	X	X	X	X	X	X	X	
518		8 1/2" Draped Lady #3	X	X			X						X	X				
849		8 1/2" Draped Lady OVAL	X								X							
516		8 1/2" Draped Lady LAMP												X				
2906		13" Draped Lady #1	X	X	X	X			X		X	X		X	X			
513	1113	13" Draped Lady #2	X	X	X	X	X	X			X	X		X	X	X	X	
1114		6" Bashful Charlotte #2	X	X	X	X					X	X		X	X			
1114		6" Bashful Charlotte #3	X															
1115		11" Bashful Charlotte #2	X	X		X	X		X		X	X		X	X			
		Rose Lady #1	X	X	X	X					X	X		X	X		X	
512	1112	Rose Lady #2	X	X	X	X					X	X		X	X			
515		Rose Lady LAMP																
508	1108	Mandolin Lady #2	X	X							X	X		X	X			
509	1109	Two-Kid #2	X	X	X	X	X		X		X	X		X	X		X	
848		Two-Kid OVAL			X									X				
523		Geisha, 1-Bun Screw	X	X	X	X					X	X		X	X		X	
522		Geisha, 2-Bun Screw	X	X	X	X		X			X	X		X	X			
1136		9" Heron #3	X															X
1111		13" Heron #2	X															
1111		13" Heron #3	X															
1137		Blue Jay #3	X			X							X	X				
1636		Blue Jay for candleholder	X			X			X				X	X				
1138		Sea Gull #2	X		X	X					X							
514		Eagle #2	X		X	X					X			X				
70		Turtle	X													X	X	
		Boy Child (Cambridge ?)									X			X				
		Bird (Cambridge ?)	X								X							

NOTE: The 2nd item number column shows numbers used for a short time in the late 1920s, then abandoned.

BASES: #1 - Large Flutes
 #2 - Round
 #3 - Small Flutes

Auction - continued from page 1

frogs, #36, #181 and #182 are joined by a rare Light Emerald centerpiece with Rose Lady, lot #311.

Hard to find colors that are in the Auction are: lot #148 Windsor Blue shell, #160 Avocado sandwich tray, #195 Sunset tumbler, #196 and #255 Rubina comports. A very rare Mardi Gras vase in an unusual shape is lot #254.

Several very nice decorations round out the rarities in the Auction. They include: lot #117 Amber gold encrusted Portia candlesticks, #227 Amethyst white gold encrusted Apple Blossom bowl and matching #228 candlesticks, #243 Carmen Tally-Ho sherbet with Rockwell Sterling, #251 Helio service plate with mint gold decoration, #257 Amethyst Japonica urn vase (note enamel nicks), #258 gold encrusted Minerva lamp, #289 Sterling Lily of the Valley decorated twin salad dressing set and #352 Blossomtime etched covered Apple with Carmen stem finial.

Remember, try to attend or mail bid.

See you there!!

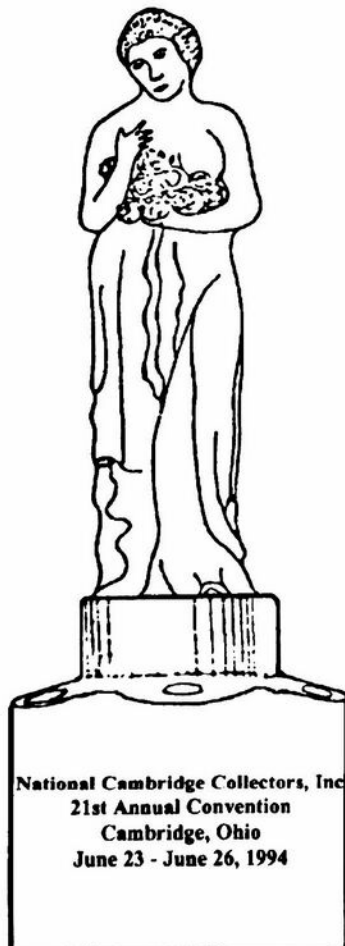

Vase Inserts - continued from page 7

half dozen flowers will serve the purpose of one or two dozen, since each flower is individually displayed and held against drooping over the vase sides.

What is claimed is:--

1. The herein described method of making flower vase inserts, which consists in pressing a mass of glass into the form of a hollow body and in confining the axial and lateral movements of the mass to form a series of spaced spikes extending axially outwardly from the upper end of the body, and simultaneously forming the body with a weakened neck having a closed bottom at the lower end of the body, then in heating the spikes and individually bending same inwardly to lie laterally of the body and with their sides spaced and with their tips arranged in a circular series surrounding the axis of the body, then in cooling, tempering, and finally in breaking off the neck and its bottom and grinding the resultant edge.

2. The hereindescribed method of making flower vase inserts, which consists in pressing a mass of glass into the form of a hollow body and in confining the axial and lateral movements of the mass to form a series of spaced spikes extending axially outwardly from an end of the body, then in heating the spikes and individually bending same inwardly to lie laterally of the body and with their sides spaced and with their tips arranged in a circular series surrounding the axis of the body.

In testimony whereof I affix my signature.
ARTHUR JAMES BENNETT.

MARK YOUR CALENDAR!

FEBRUARY QUARTERLY MEETING
7:30 pm **FRIDAY, MARCH 4, 1994**
New Location - Pritchard Laughlin Civic Center

AUCTION 94
SATURDAY, MARCH 5, 1994
New Location - Pritchard Laughlin Civic Center
9:00 am - Preview 10:00 am - Auction

1994 CONVENTION
JUNE 23, 24, 25, 26, 1994

INVENTORY CLEARANCE SALE

(All Prices Each)

Cup Plates - Crystal, Cobalt, Amethyst or Teal	4.00
Scotty Dog Book Ends - Ebony Frosted, marked '1979 NCC'	15.00
Eagle Book Ends - Cobalt Blue	30.00
NCC Convention Favors:	
1980 Windsor Paperweight	5.00
1982 Gold Paperweight	5.00
1983 Blue Georgian Tumbler	5.00
1984 Amber Georgian Tumbler	5.00
1985 Pink Georgian Tumbler	5.00
1986 Gold Georgian Tumbler	5.00
1987 Light Blue Nearcut Martha Punch Cup	5.00
1988 Cobalt Cambridge Square Cigarette Holder	8.00
1989 Teal Mt. Vernon Cordial	8.00
1990 Pink Mt. Vernon Cordial	8.00
1991 Cobalt Mt. Vernon Cordial	8.00
1992 Ebony Mt. Vernon Cordial	8.00
1993 Light Green Caprice Ash Tray	7.00

Items by Cambridge Buff's Study Group:	
Lapel pins, black & gold	1.00
Tie tacks, black & gold	1.00

Postage & Insurance Extra
Ohio Residents Add 6½% Sales Tax

National Cambridge Collectors, Inc.
PO Box 416
Cambridge, OH 43725-0416

ADDITIONAL BOOKS FOR SALE

By the Degenhart Paperweight and Glass Museum

- **Reflections**
45 pages, histories of all glass factories in
Guernsey County, Ohio
Paperback (includes postage) \$5.00

*By Hector Bolitho
& the Jamestown Glasshouse Foundation*

- **The Glass House - Jamestown Virginia**
32 pages giving history and restoration of the
first glasshouse in America
Paperback (includes postage) \$1.50

The
DAZE Inc.

SPECIAL OFFER
to NCC friends
\$2.00 OFF
the 1 year subscription price
when on this form or copy of it.

The Original National monthly newspaper dedicated to the buying, selling and collecting of colored glassware and china including Depression Glass and the Elegant Glass (Cambridge, Heisey, Fostoria, etc.) We educate and inform you each month with feature articles by top notch columnists, readers "finds", club happenings, show news and a multitude of ads. Find those missing pieces to your 30s, 40s, or 50s pattern. Can't identify it? Perhaps we can help "keep up with what's happening" with a subscription to the DAZE. Buy, sell or trade from the convenience of your easy chair.

Name _____
Street _____
City _____
State _____ Zip _____

1 year \$21.00 2 years \$40.00 \$2.00 Single Copy

Exp. Date _____ Card No. _____
Signature _____

Orders to:
The Daze, Inc., Box 57, Otisville, MI 48463
Please allow 30 days for your first issue - Canadian Subscribers, add \$1 00 per year and subscribe by charge card only! This Special Offer may not be combined with any other special offer.
Offer Expires December 31, 1994

Classified

WANTED TO BUY: Rose Point #3106 stems and swans. Write price and description. **Nancy & Jim Finley**, 711 West Broadway, Sedalia, MO 65301. Phone: (816) 826-5032 or 827-0101.

GLASS EPERGNES WANTED: New York City epergne collector seeking epergnes of any origin. Particularly desirous of unusual shapes, colors, those with hanging baskets or tulips, and any which are of definite American manufacture. Send photos only: **Ann Aikens**, 810 7th Ave, 36th floor, New York, NY 10019. Phone (212) 830-2072. Fax (212) 830-5199.

WANTED: Advertisers interested in good results and value for the advertising dollar to advertise in this space. Classified ads in the Cambridge CRYSTAL BALL cost only 10¢ per word (\$2 minimum). Ad copy must be received by the 5th of each month to appear in the next issue. **National Cambridge Collectors, Inc.** PO Box 416, Cambridge, OH 43725

ISAACS ANTIQUES



WE FEATURE GLASSWARE OF: CAMBRIDGE,
HEISEY, FENTON & FOSTORIA
Plus Art Pottery & a General Line of Antiques

DORIS AND ROY ISAACS
BUY AND SELL
614-872-3720

7525 East Pike
Norwich, Ohio 43767
614-872-3720

In East Pike Antique Complex - Rt. 40,
One Mile West of I-70 Norwich Exit #164

Hours 10 - 5:30 Mon. - Sat.
12 - 5:30 Sun.
Open Year Round

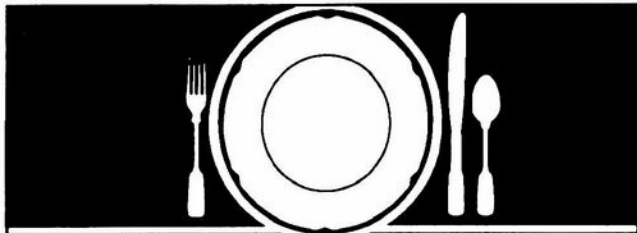
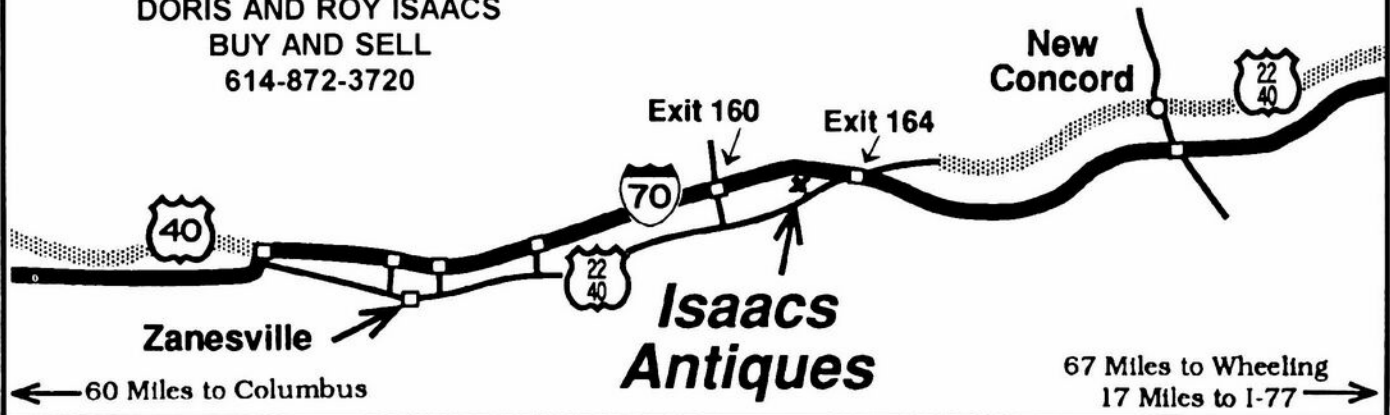

How to Find Those Missing Pieces.

The world's largest source of discontinued and obsolete crystal -- as well as china and flatware -- Replacements, Ltd., buys and sells over 36,000 different patterns.

If you need a piece or several pieces to add to your collection ... or if you'd like to sell some unneeded extras ... call or write us. We can provide you with a complete printout of available pieces in your pattern. Or we'll let you know our prices for the pieces you wish to sell.

Replacements, Ltd.: a 100,000 square foot facility; 1.4 million pieces; over 600,000 satisfied customers. Contact us, or come see our showroom. Let us help you complete your collection ... or maybe you'll help add to ours.

REPLACEMENTS, LTD.

Call (919) 697-3000, FAX (919) 697-3100, or write:
1089 Knox Road • P. O. Box 26029, Dept. C • Greensboro, NC 27420

OVER 6800 CAMBRIDGE PIECES

WE CLEAN CLOUDY GLASS!

**** SATISFACTION GUARANTEED ****

YES, IT IS TRUE THAT WE REALLY CAN RESTORE THE INTERIOR OF YOUR CRUET, VASE, DECANTER AND MOST OTHER INTERNALLY ETCHED ITEMS BACK TO NEAR ORIGINAL CONDITION!

WE DO NOT OIL, WAX OR COVER UP THE SICKNESS IN ANY WAY! WE ACTUALLY REMOVE IT.

NO ITEMS ARE TOO SICK TO CLEAN! IF WE CANNOT CLEAN YOUR ITEM TO MEET YOUR SATISFACTION, THE CLEANING IS FREE!

WE ARE SO CONFIDENT IN OUR SERVICE THAT WE ASK THAT YOU SEND NO MONEY. WHEN WE RETURN YOUR ITEM A BILL WILL BE ENCLOSED FOR THE POSTAGE & CLEANING. IF YOU ARE HAPPY, PLEASE SEND PAYMENT; IF NOT, RETURN THE BILL MARKED "NOT SATISFIED".

PLEASE ALLOW 6-8 WEEKS FOR REDELIVERY OF MOST ITEMS. ALL GLASS IS HANDLED AND CLEANED AT YOUR RISK. SOME VERY CLOUDY ITEMS MAY TAKE SEVERAL ADDITIONAL WEEKS.

CRUET	\$20.00	COCKTAIL SHAKER	\$30.00
COLOGNE	\$20.00	SALT SHAKER (SINGLE)	\$15.00
WATER BOTTLE	\$30.00	SALT SHAKER (PAIR)	\$25.00
DECANTER	\$30.00	CRUSHED FRUIT JAR	\$30.00
VASES (UNDER 12 IN.)	\$25.00	LAVENDER JAR	\$20-30.00

ALL OTHERS WRITE FOR QUOTE

SHIP TO: CARLISLE & ASSOCIATES
28220 LAMONG ROAD, DEPT. C
SHERIDAN IN 46069
(317) 758-5767 AFTER 6:00 P.M.

DEALERS



DIRECTORY

NOTE: When writing to the Dealers listed here, please enclose a SASE!

<p>DAUGHERTY'S ANTIQUES Jerry and Shirley Antiques and Collectibles * Mostly Glass Shows & Mail Orders 2515 Cheshire No. 402-423-7426 Evenings Lincoln NE 68512</p>	<p>"HAPPINESS IS" Buddy and Kathy Stultz 3106 Warren Court, Glen Allen, VA 23060 804-672-8102 Specializing in American Made Glass We Buy & Sell, Shows & Mail Order</p>	<p>THE MUTED SWAN ANTIQUES 5486 Peachtree Rd. Chamblee, GA 30341 Heart of Chamblee Antique Row Specializing in Cambridge, Heisey and Fostoria Bill & Pat Miller 404-451-7620</p>
<p>MILBRA'S CRYSTAL MATCHING P.O. Box 363, Rio Vista, TX 76093 Milbra Long 817-645-6066 FOSTORIA * CAMBRIDGE * HEISEY TIFFIN, LENOX, OTHERS BUY AND SELL</p>	<p>WATKINS (Fine Quality) CAMBRIDGE GLASS SHOP 1429 Marquand Ave. (Corner of Woodlawn) Cambridge, OH 614-432-4460 Lana Watkins</p>	<p>ARMORY ANTIQUES 168 West Main Street Plain City, OH 43064 QUALITY THINGS Cambridge, Heisey, China, Silver, Furniture Mon-Sat 10-5 VISA/MC 614-873-4890</p>
<p>THE GLASS URN 456 West Main Street, Suite G Mesa, AZ 85201 602-833-2702 Mail Order Shows Open Shop CAMBRIDGE, FOSTORIA, HEISEY, ETC.</p>	<p>ANTIQUES ON THE MALL SPECIALIZING IN CAMBRIDGE GLASS Bogart's - Bldg #3 - Norwich, OH Virginia Bennett 614-432-4483 64183 Warne Drive, Cambridge, OH 43725</p>	<p>GATEWAY ANTIQUE MALL, INC. JUST NW OF MINNEAPOLIS-ST PAUL, MN NE Corner Intersection of I-94/101, Rogers, MN (Look for our High Sign) 50 Dealers 7 Days, 10-6 612-428-8286 ELAINE STORCK, DIRECTOR</p>
<p>ETTELMAN'S DISCONTINUED CHINA & CRYSTAL Cambridge a Speciality P.O.Box 6491-CB Corpus Christi TX 78466 Phone 512-888-8391 Include S.A.S.E.</p>	<p>D & D ANTIQUES Columbus, Ohio Dick Slifko SHOWS ONLY</p>	<p>RONI SIONAKIDES 6565 W. Herbison Rd. DeWitt, MI 48820 517-669-5981 Fostoria, Tiffin, Duncan, Cambridge</p>
<p>THE GLASS CUPBOARD P. O. Box 652 West End, North Carolina 27376 Marcia Ellis Cambridge, Duncan, Heisey 919-673-2884 Shows, Mail Order</p>	<p>JUDY'S ANTIQUES Judy Bennett 422 S. Ninth Street (Corner of Jefferson) Cambridge, Ohio 43725 BUYING Ph.614-432-5855 SELLING CAMBRIDGE GLASS MY SPECIALTY</p>	<p>YOU CAN ADVERTISE YOUR ANTIQUE SHOP HERE!</p>
<p>ELEGANT GLASSWARE Barbara & Cindy Brock Rt. 1, Box 66AC, Callands, VA 24530 804-724-6762 Cambridge - Heisey - Duncan - Fostoria</p>	<p>GREEN ACRES FARM 2678 Hazelton Etna Rd., Pataskala, OH 43062 (State Route 310 North) Sat & Sun 1-7 PM 614-927-1882 Antiques, Crystal Glass and Collectibles</p>	<p>CRYSTAL LADY 1817 Vinton St., Omaha, NE 68108 Joann D. Hagerty Bus. 402-341-0643 Res. 402-391-6730 Specializing in Elegant Glass & Collectibles</p>
<p>YOU CAN ADVERTISE YOUR ANTIQUE SHOP HERE!</p>	<p>FLORENCE SOLITO 54 Old Stafford Rd, Tolland CT 06084 Stock All Elegant Glassware Mail Order Since 1978 Send Wants 203-872-3294 Satisfaction Guaranteed</p>	<p>YOU CAN ADVERTISE YOUR ANTIQUE SHOP HERE!</p>
<p>YOU CAN ADVERTISE YOUR ANTIQUE SHOP HERE!</p>	<p>REMEMBRANCES 7597 Daphne Dr., No. Syracuse NY 13212 Shirley S. Ladouceur 315-458-5297 ANTIQUES and COLLECTIBLES MAIL ORDER SHOWS APPOINTMENTS</p>	<p>MARGARET LANE ANTIQUES 2 E. Main St., New Concord, OH 43762 Lynn Welker 614-826-7414 Cambridge Glass Matching Service Hours Mon-Fri 10-12AM, 1-5PM or by Appointment</p>
<p>GLASS RESTORATION BRILLIANT DON & LYNNE CRYSTAL WORMLAND ELEGANT MT. CLEMENS, MICH DEPRESSION 313-468-3519</p>	<p>YOU CAN ADVERTISE YOUR ANTIQUE SHOP HERE!</p>	<p>HELEN & JIM KENNON Heisey, Cambridge, Fostoria, Duncan, Imperial, Fenton, Tiffin P.O. Box 114, Brookville, OH 45309 PH: 513-833-5406 SHOWS ONLY</p>

LIMITED EDITION
Cambridge PRISM SIGN

250 LIMITED EDITION FUND RAISING PROJECT
 TOMATO CREAM PRISM, FIRST IN SERIES
 [Orders may exceed supply. Prisms may be sold out]

National Cambridge Collector's Inc. has begun a significant new fund-raising project to benefit exclusively the NCC Museum. Members support will guarantee the maintenance of a top-flight museum, consistent with the charter of the organization.

Boyd's Crystal Art Glass has been selected to make this first issue commemorative prism sign. The color will be Tomato Cream. It starts with a beautiful red at the edges of the piece shading to a rich yellow in the center. Some say it's similar to a tomato ripening on the vine.

Only 250 prism signs will be produced. No more. Even if you beg us! So act now, and don't get shut out. If the membership responds, additional colors may be produced in the future. You'll want to build a whole set. These will be major NCC collector's items. And, you'll be supporting your museum.

Given the expected demand, we're limiting purchase to 2 per member (master or associate). The Prism is an affordable \$16.00 each. Ohio members must add 6½% sales tax. Shipping is \$2.00 extra per order.

ACT NOW. SUPPORT YOUR NCC MUSEUM.
AVOID SHIPPING CHARGES. GET YOUR PRISM AT MARCH'S MEETING.
 Make all checks payable to: NCC, Inc., P.O. Box 416, Cambridge, Ohio 43725-0416

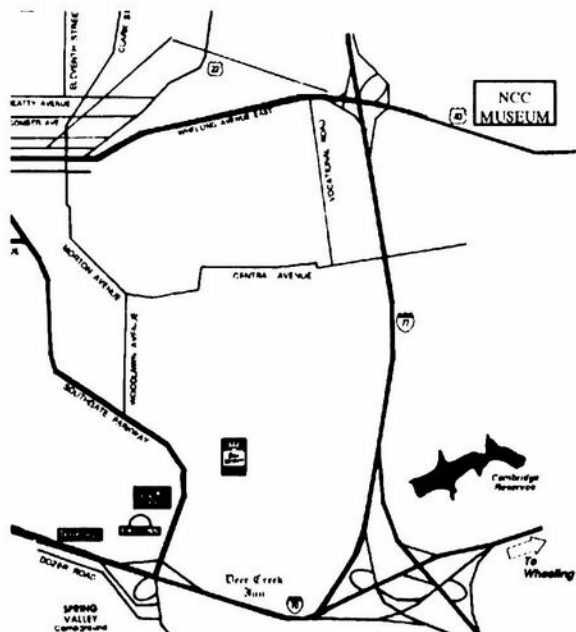

NCC Museum of Cambridge Glass

The museum is located on U.S. Route 40, one-eight mile east of I-77 near Cambridge. Hours: 9 a.m. to 4 p.m., Wednesday through Saturday; noon to 4 p.m., Sunday (March through October). Phone 614-432-4245. Closed Mondays, Tuesdays, Easter and the 4th of July. Also closed Wednesday and Thursday - March only.

Membership Renewal Notice

This is your last issue of the *CRYSTAL BALL*, if the date on your address label reads 3/94.

Please renew now!

National Cambridge Collectors, Inc.
 P.O. Box 416, Cambridge, Ohio 43725-0416

NON PROFIT
 ORGANIZATION
 U. S. POSTAGE
PAID
 Dayton, OH
 Permit #974

FORWARDING AND RETURN
 POSTAGE GUARANTEED

PLEASE DELIVER PROMPTLY, DATED MATERIAL.

